

Painting Cell for Medium-Size Applications

Servo Spinner

A New Dimension in "Line Coating"

KEY FEATURES

Flexible Configuration

Ultimate flexibility of paint cell components and incoming parts location help increase production, reduce plant floor modifications while minimizing booth contamination.

Uninterrupted Painting

The robot wait time is reduced to a minimum as painting is performed while the table is rotating without having to remove the parts from the production line.

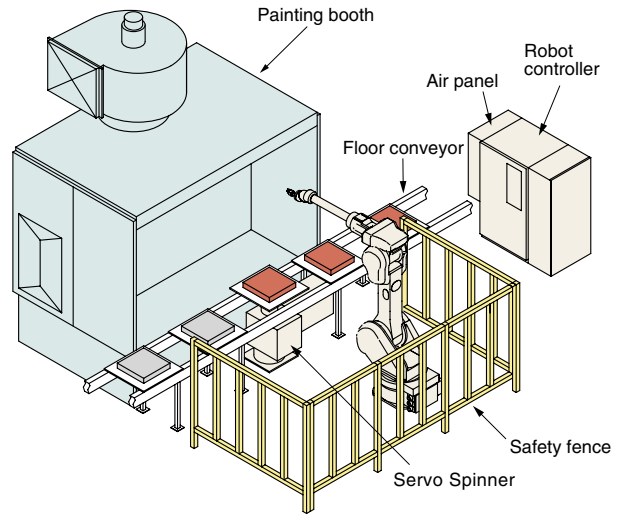

SPECIFICATIONS

		STANDARD	HEAVY LOAD CARRYING
Table Load		20 kg	60 kg
No. of Control Axes		6-Axis Robot + 1-Axis Servo Spinner	
Control Method		Servo Control	
Programming Method		Point-to-Point Teaching/Off-line Programming/AS Language	
Position Detection Method		Absolute Encoder	
Table	Operation Angle	Infinite Revolution	
	Indexing Angle	90° and Arbitrary Angle	
	Indexing Time	0.8 sec./90°	1.1 sec./90°
	Uninterrupted Rotary Speed	Max. 90 rpm	Max. 45 rpm
	Rotary Direction	Normal/Reverse Rotation	
Explosion Protection		Pressurized and Intrinsically Safe (class 1, zone 1, group IIB & T4 certified)*	
Mass		60 kg	
Color		Kawasaki Standard	

Note: The work piece table, fixtures, conveyor, paint booth, and other equipment to be supplied by purchaser.

*Contact KRI for latest certification.

EXTERNAL VIEW AND DIMENSIONS

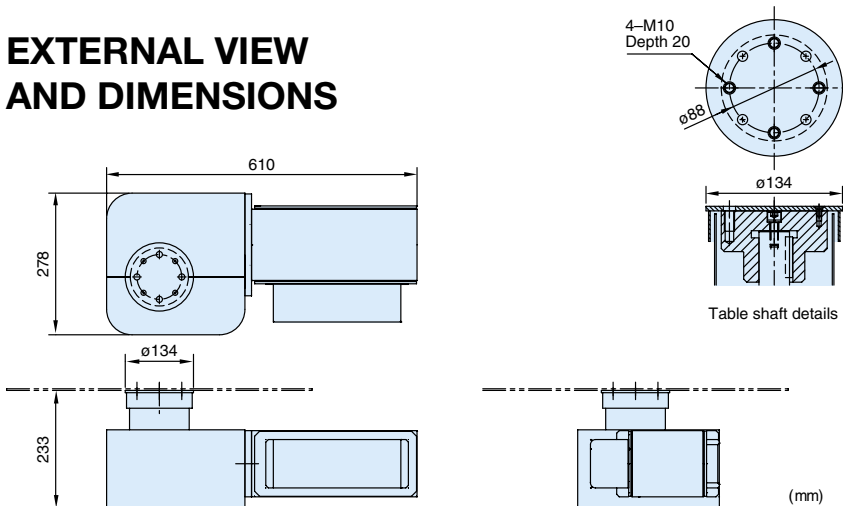

Kawasaki Robotics (USA), Inc.
28140 Lakeview Drive · Wixom, Michigan 48393
Phone: (248) 446-4100 Fax: (248) 446-4200

Louisville, Kentucky
2726 River Green Circle · Louisville, Kentucky 40206
Phone: (502) 893-3889 Fax: (502) 893-3830

San Jose, California
3081 North First Street · San Jose, California 95134
Phone: (408) 432-0990 Fax: (408) 432-0996

Kawasaki Robotics (USA), Inc. - Canada
1155 North Service Road West, Suite #4 · Oakville, Ontario L6M 3E3
Phone: (905) 465-0880 Fax: (905) 465-1221

Kawasaki Robotics (USA), Inc. - Mexico
Av. Vallarta #6503 Local B 9
Concentro Zapopan, Jalisco 45010, Mexico
Phone: (52) 33 3110-1895 Fax: (52) 33 3110-1897

www.KawasakiRobotics.com