

Standard Applications:

- Arc Welding
- Dispensing
- Sealing
- Material Handling
- Material Removal
- Machine Tending
- Assembly
- Inspection

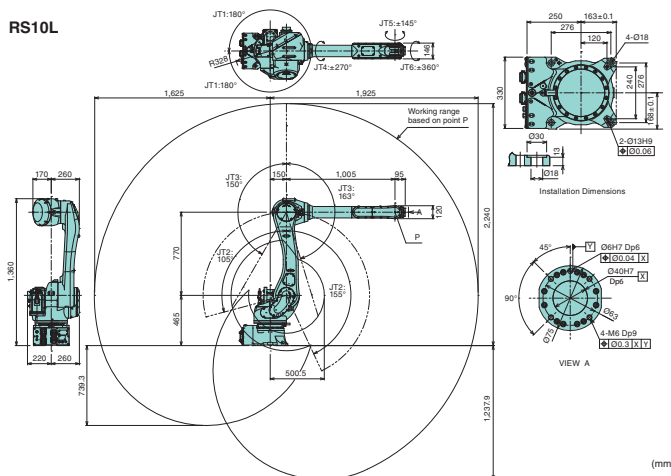

RS10L



Arm Type	Articulated		
Degrees of Freedom	6		
Axes Work Envelope and Maximum Speed	Axis	Work Envelope	Maximum Speed
	Arm Rotation (JT1)	± 180°	190° /s
	Arm Out-In (JT2)	+155° ~ -105°	205° /s
	Arm Down-Up (JT3)	+150° ~ -163°	210° /s
	Wrist Swivel (JT4)	± 270°	400° /s
	Wrist Bend (JT5)	± 145°	360° /s
	Wrist Twist (JT6)	± 360°	610° /s
Position Repeatability	±0.06 mm		
Payload	10 kg		
Maximum Speed	13,100 mm/s		
Wrist Load Capacity	(kgf * m * s ²) (kg * mm ²) (Note)		
		Torque	Moment of Inertia
	JT4	22 N*m	0.7 kg*m ²
	JT5	22 N*m	0.7 kg*m ²
	JT6	10 N*m	0.2 kg*m ²
* Note: each value in this table shows allowable moment of inertia of JT4/JT5/JT6 when maximum allowed torque is applied to each axis. If more detailed data is required for your application, please contact Kawasaki.			
Driving Motor	Brushless AC Servomotor		
Mass	230 kg (excluding options)		
Color	Kawasaki Standard		
Installation	Floor, Ceiling and Wall Mount		
Ambient Temperature	0 ~ 45° C for manipulator		
Relative Humidity	35 ~ 85% no dew nor frost allowed		
Power/Signal Cable Length	7 m		
IP Rating	IP67 Base Axis:IP65		
Built-in Circuit	Built-in Sensor Harness; 4 Circuits, 24 VDC, GND		
Pneumatic Piping	Built-in Pneumatic Piping		
Options	Power/Signal Cable Length: 10 m, 15 m		
	Built-in Valve		
	Riser		
Consult us about Maintenance Parts and Spare Parts.			